

# 8560 8760, and 8960 Tractors Repair

For complete service information also see:

8560, 8760, and 8960 Tractors

Operation and Tests . . . . . TM1434

6076 Engine

Serial Number ( -499999) . . . . . CTM6

Serial Number (500000- ) . . . . . CTM42

6101 Engine . . . . . CTM20

Radial Piston Pumps . . . . . CTM7

Engine Accessories . . . . . CTM11

1600 Series Axles . . . . . CTM18

**John Deere Waterloo Works**  
**TM1433 (19JUL01)**

LITHO IN U.S.A.  
ENGLISH

# Introduction

## FOREWORD

This manual is written for an experienced technician. Essential tools required in performing certain service work are identified in this manual and are recommended for use.

Live with safety: Read the safety messages in the introduction of this manual and the cautions presented throughout the text of the manual.



This is the safety-alert symbol. When you see this symbol on the machine or in this manual, be alert to the potential for personal injury.

Technical manuals are divided in two parts: repair and diagnostics. Repair sections tell how to repair the components. Diagnostic sections help you identify the majority of routine failures quickly.

Information is organized in groups for the various components requiring service instruction. At the beginning of each group are summary listings of all applicable essential tools, service equipment and tools, other materials needed to do the job, service parts kits, specifications, wear tolerances, and torque values.

Binders, binder labels, and tab sets can be ordered by John Deere dealers direct from the John Deere Distribution Service Center.

This manual is part of a total product support program.

## FOS MANUALS—REFERENCE

## TECHNICAL MANUALS—MACHINE SERVICE

## COMPONENT MANUALS—COMPONENT SERVICE

Fundamentals of Service (FOS) Manuals cover basic theory of operation, fundamentals of troubleshooting, general maintenance, and basic type of failures and their causes. FOS Manuals are for training new personnel and for reference by experienced technicians.

Technical Manuals are concise guides for specific machines. Technical manuals are on-the-job guides containing only the vital information needed for diagnosis, analysis, testing, and repair.

Component Technical Manuals are concise service guides for specific components. Component technical manuals are written as stand-alone manuals covering multiple machine applications.

## NOTICE TO THE DEALER

**IMPORTANT: The changes listed below make your current TM obsolete. Discard TM1433 dated 23MAY91. Please make this information available to your service department.**

• SECTION 20—

Dynamometer Test moved to TM1434

• SECTION 30—

Some information has been eliminated since it appears in the Operator's Manual

• SECTION 40—

Added New Wiring Harnesses  
Added Hitch Draft Sensing

• SECTION 50—

24-Speed MST Hi-Lo Clutch Changes  
Revised Section 50 Groups

• SECTION 55—

Revised Transmission Repair Procedures

• SECTION 60—

Added Steering Valve Warm-up Check Valve

• SECTION 70—

Added New Hydraulic Circuit  
Revised Section 70 Groups

• SECTION 80—

Revised Wheels—Group 05

• SECTION 90—

Revised Air Quality System Repair

*Major revisions to this TM are listed above. Some Sections and Groups will have specification, procedure, or formatting changes not listed on this notification.*

RX, TM1433, DLR -19-09MAR92

# Contents

## SECTION 05—SAFETY

Group 05—Safety

## SECTION 10—GENERAL INFORMATION

Group 05—Machine Specifications

Group 10—Predelivery

Group 15—Tune-up

Group 20—Lubrication

## SECTION 15—Component Removal

Group 00—Major Components

Group 05—Front Axles and Final Drives

Group 10—Rear Axles and Final Drives

Group 15—Engine

Group 20—SOUND-GARD Body

Group 25—Mechanical Shift Transmission

Group 30—Power Shift Transmission

## SECTION 20—ENGINES

Group 05—Engine Service

Group 10—Cooling System

## SECTION 30—FUEL AND AIR SYSTEMS

Group 05—Air Intake System

Group 10—Diesel Fuel System

## SECTION 40—ELECTRICAL

Group 01—Batteries

Group 05—Electrical Components and Wiring  
Harnesses

Group 10—Connectors

Group 15—Alternator

Group 20—Starting Circuit

Group 25—Lighting Circuit

Group 30—INTELLITRAK Monitoring System

Group 35—Accessory Components

Group 40—Hitch Electronic Control Components

Group 45—PST Electronic Control Components

## SECTION 50—MECHANICAL SHIFT TRANSMISSION

Group 05—Transmission Oil Filter Relief Valve  
Housing

Group 10—Transmission Control Valve Housing

Group 15—Transmission Pump

Group 20—Transmission Front Cover

Group 25—Hi-Lo Clutch and Brake (24-Speed)

Group 30—Hi-Lo Planetary (24-Speed)

Group 35—Spacer Housing

Group 40—Traction Clutch

Group 45—Transmission Gear Train

Group 50—Transmission Clean-Up

Group 55—Shift Levers and Linkage

## SECTION 55—POWER SHIFT TRANSMISSION

Group 05—Transmission Oil Filter Relief Valve  
Housing and Oil Pump

Group 10—Transmission Pressure Regulating  
Valve

Group 15—On-Off and Modulating Shift Solenoids

Group 20—8-Inch Clutch Assembly

Group 25—Lower 7-Inch Clutch Assembly

Group 30—Upper 7-Inch Clutch Assembly

Group 35—Compound Shaft Assembly

Group 40—9-Inch Clutch Assembly

Group 45—Front and Rear Housings

Group 50—Transmission Clean-Up

Group 55—Shift Selector Assembly

## SECTION 56—POWER TRAIN COMPONENTS

Group 05—Engine Coupler

Group 10—Drive Shafts

Group 15—PTO Clutch

Group 20—PTO Clutch Valve and Linkage

Group 25—PTO Drop Box

## SECTION 60—STEERING AND BRAKES

Group 05—Steering Column

Group 10—Metering Pump

Group 15—Steering Valve

Group 20—Steering Cylinder

Group 25—Feedback Cylinder

Continued on next page

*All information, illustrations and specifications in this manual are based on the latest information available at the time of publication. The right is reserved to make changes at any time without notice.*

TM1433-19-19JUL01

COPYRIGHT© 1992  
DEERE & COMPANY  
Moline, Illinois

All rights reserved  
A John Deere ILLUSTRATION® Manual  
Previous Editions  
Copyright 1991, 1990 Deere & Company

Group 30—Brake Valve and Brake Accumulator

05

**SECTION 70—HYDRAULICS**

Group 05—Hydraulic System Repair

Group 10—Main Hydraulic Pump

Group 15—Axle Lube and Charge Pumps  
(P.I.N. -XXXX)

10

Group 20—Charge-Lube Pump (P.I.N. XXXX- )

Group 25—Filter Housing, Bypass Valves, and  
Reservoir (P.I.N. -XXXX)

Group 30—Filter Housing, Bypass Valves, and  
Reservoir (P.I.N. XXXX- )

15

Group 35—Oil Cooler and Control Valves

Group 40—Hitch

Group 45—Hitch Valve and Selective Control  
Valves

Group 50—Lift Cylinders

20

Group 55—Hydraulic System Clean-up

Group 60—Remote Cylinder

**SECTION 80—MISCELLANEOUS**

Group 05—Wheels

Group 10—Gudgeon

30

**SECTION 90—OPERATOR STATION**

Group 05—Air Conditioning System Repair

Group 10—Air Conditioning System Service

Group 15—HYDRACUSHION Seat

Group 20—Miscellaneous Components

40

**SECTION 99—DEALER FABRICATED TOOLS**

Group 05—Fabricated Tools

50

**Index**

55

56

60

# Section 05 SAFETY

05

## Contents

Page

Group 05—Safety .....	05-05-1
-----------------------	---------

## HANDLE FLUIDS SAFELY—AVOID FIRES

When you work around fuel, do not smoke or work near heaters or other fire hazards.

Store flammable fluids away from fire hazards. Do not incinerate or puncture pressurized containers.

Make sure machine is clean of trash, grease, and debris.

Do not store oily rags; they can ignite and burn spontaneously.



DX,FLAME -19-04JUN90

TS227 -JUN-23AUG88

05  
1

## PREVENT BATTERY EXPLOSIONS

Keep sparks, lighted matches, and open flame away from the top of battery. Battery gas can explode.

Never check battery charge by placing a metal object across the posts. Use a volt-meter or hydrometer.

Do not charge a frozen battery; it may explode. Warm battery to 16°C (60°F).



DX,SPARKS -19-04JUN90

TS204 -JUN-23AUG88

## PREPARE FOR EMERGENCIES

Be prepared if a fire starts.

Keep a first aid kit and fire extinguisher handy.

Keep emergency numbers for doctors, ambulance service, hospital, and fire department near your telephone.

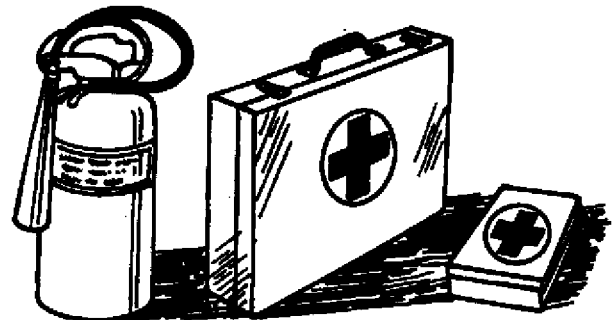

DX,FIRE2 -19-04JUN90

TS291 -JUN-23AUG88

## PREVENT ACID BURNS

Sulfuric acid in battery electrolyte is poisonous. It is strong enough to burn skin, eat holes in clothing, and cause blindness if splashed into eyes.

Avoid the hazard by:

1. Filling batteries in a well-ventilated area.
2. Wearing eye protection and rubber gloves.
3. Avoiding breathing fumes when electrolyte is added.
4. Avoiding spilling or dripping electrolyte.
5. Use proper jump start procedure.

If you spill acid on yourself:

1. Flush your skin with water.
2. Apply baking soda or lime to help neutralize the acid.
3. Flush your eyes with water for 10—15 minutes. Get medical attention immediately.

If acid is swallowed:

1. Drink large amounts of water or milk.
2. Then drink milk of magnesia, beaten eggs, or vegetable oil.
3. Get medical attention immediately.

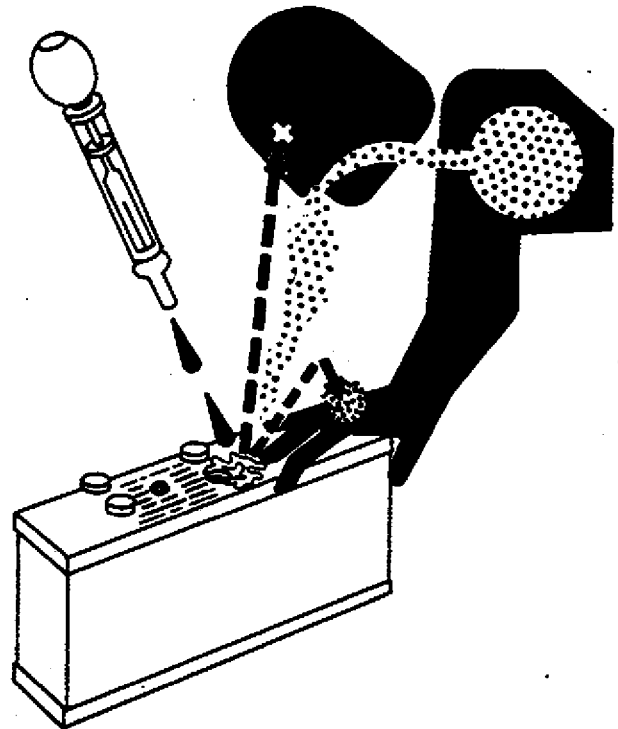

DX, POISON -19-04JUN90

TS203 -UN-23AUG88

## HANDLE CHEMICAL PRODUCTS SAFELY

Direct exposure to hazardous chemicals can cause serious injury. Potentially hazardous chemicals used with John Deere equipment include such items as lubricants, coolants, paints, and adhesives.

A Material Safety Data Sheet (MSDS) provides specific details on chemical products: physical and health hazards, safety procedures, and emergency response techniques.

Check the MSDS before you start any job using a hazardous chemical. That way you will know exactly what the risks are and how to do the job safely. Then follow procedures and recommended equipment.

(See your John Deere dealer for MSDS's on chemical products used with John Deere equipment.)

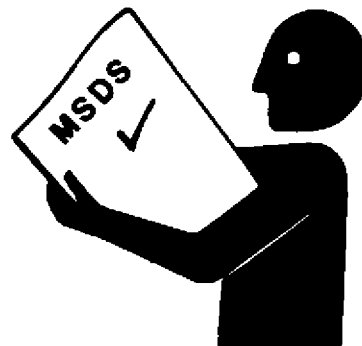

DX, MSDS, NA -19-15MAR91

TS1132 -UN-26NOV90



## AVOID HIGH-PRESSURE FLUIDS

Escaping fluid under pressure can penetrate the skin causing serious injury.

Avoid the hazard by relieving pressure before disconnecting hydraulic or other lines. Tighten all connections before applying pressure.

Search for leaks with a piece of cardboard. Protect hands and body from high pressure fluids.

If an accident occurs, see a doctor immediately. Any fluid injected into the skin must be surgically removed within a few hours or gangrene may result. Doctors unfamiliar with this type of injury should reference a knowledgeable medical source. Such information is available from Deere & Company Medical Department in Moline, Illinois, U.S.A.

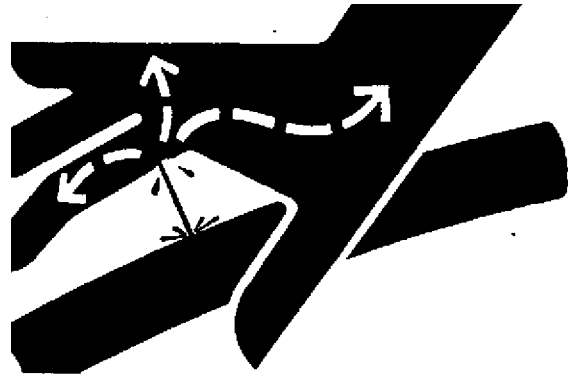

DX,FLUID -19-09AUG91

-JUN-23AUG88

X9811

05  
05  
3

## PARK MACHINE SAFELY

Before working on the machine:

- Lower all equipment to the ground.
- Stop the engine and remove the key.
- Disconnect the battery ground strap.
- Hang a "DO NOT OPERATE" tag in operator station.

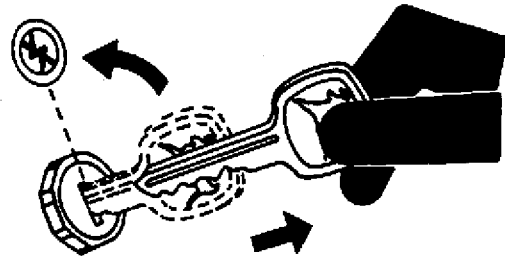

DX,PARK -19-04JUN90

-JUN-24MAY89

TS230

05  
05  
4

### SUPPORT MACHINE PROPERLY

Always lower the attachment or implement to the ground before you work on the machine. If you must work on a lifted machine or attachment, securely support the machine or attachment.

Do not support the machine on cinder blocks, hollow tiles, or props that may crumble under continuous load. Do not work under a machine that is supported solely by a jack. Follow recommended procedures in this manual.

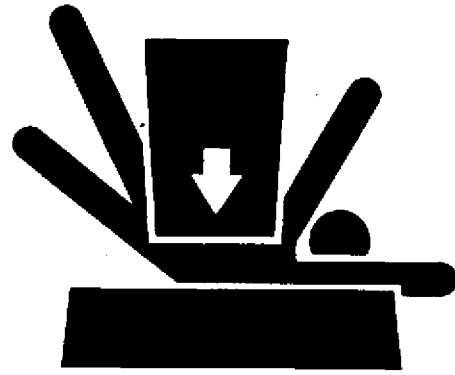

DX,LOWER -19-04JUN90

TS229 -JUN-23AUG88

### WEAR PROTECTIVE CLOTHING

Wear close fitting clothing and safety equipment appropriate to the job.

Prolonged exposure to loud noise can cause impairment or loss of hearing.

Wear a suitable hearing protective device such as earmuffs or earplugs to protect against objectionable or uncomfortable loud noises.

Operating equipment safely requires the full attention of the operator. Do not wear radio or music headphones while operating machine.

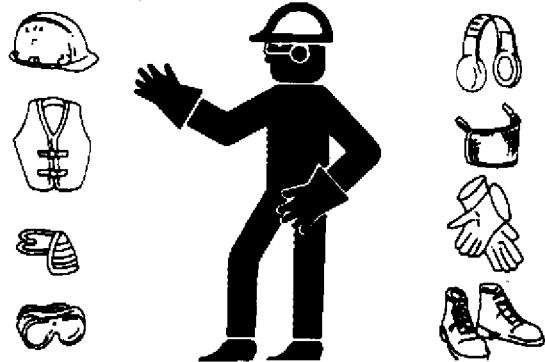

DX,WEAR -19-10SEP90

TS206 -JUN-23AUG88

### WORK IN CLEAN AREA

Before starting a job:

- Clean work area and machine.
- Make sure you have all necessary tools to do your job.
- Have the right parts on hand.
- Read all instructions thoroughly; do not attempt shortcuts.

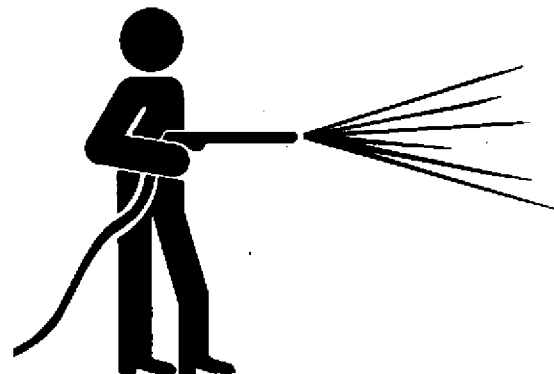

DX,CLEAN -19-04JUN90

T6642EJ -JUN-18OCT88

### SERVICE MACHINES SAFELY

Tie long hair behind your head. Do not wear a necktie, scarf, loose clothing, or necklace when you work near machine tools or moving parts. If these items were to get caught, severe injury could result.

Remove rings and other jewelry to prevent electrical shorts and entanglement in moving parts.

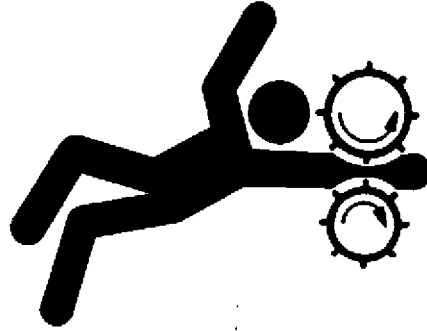

DX, LOOSE -19-04JUN90

TS228 -JUN-23AUG88

5195

### WORK IN VENTILATED AREA

Engine exhaust fumes can cause sickness or death. If it is necessary to run an engine in an enclosed area, remove the exhaust fumes from the area with an exhaust pipe extension.

If you do not have an exhaust pipe extension, open the doors and get outside air into the area.

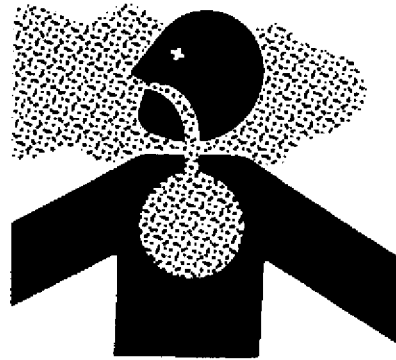

DX, AIR -19-04JUN90

TS220 -JUN-23AUG88

### ILLUMINATE WORK AREA SAFELY

Illuminate your work area adequately but safely. Use a portable safety light for working inside or under the machine. Make sure the bulb is enclosed by a wire cage. The hot filament of an accidentally broken bulb can ignite spilled fuel or oil.



DX, LIGHT -19-04JUN90

TS223 -JUN-23AUG88

### REPLACE SAFETY SIGNS

Replace missing or damaged safety signs. See the machine operator's manual for correct safety sign placement.

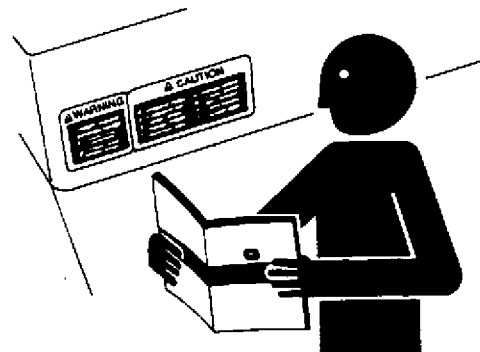

DX, SIGNS1 -19-04JUN90

TS201 -JUN-23AUG88

05-05-6

### USE PROPER LIFTING EQUIPMENT

Lifting heavy components incorrectly can cause severe injury or machine damage.

Follow recommended procedure for removal and installation of components in the manual.

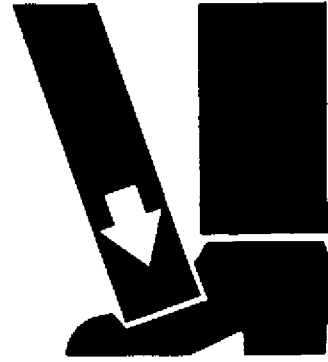

DX,LIFT -19-04JUN90

TS226 -JUN-23AUG88

### SERVICE TIRES SAFELY

Explosive separation of a tire and rim parts can cause serious injury or death.

Do not attempt to mount a tire unless you have the proper equipment and experience to perform the job.

Always maintain the correct tire pressure. Do not inflate the tires above the recommended pressure. Never weld or heat a wheel and tire assembly. The heat can cause an increase in air pressure resulting in a tire explosion. Welding can structurally weaken or deform the wheel.

When inflating tires, use a clip-on chuck and extension hose long enough to allow you to stand to one side and NOT in front of or over the tire assembly. Use a safety cage if available.

Check wheels for low pressure, cuts, bubbles, damaged rims or missing lug bolts and nuts.

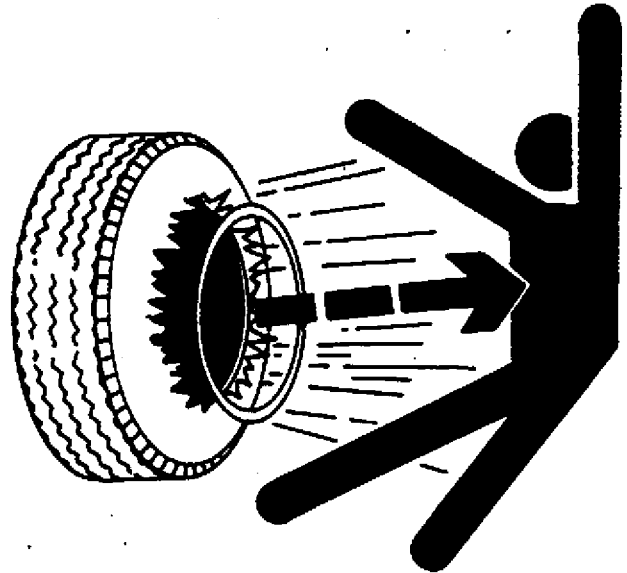

DX,RIM -19-24AUG90

TS211 -JUN-23AUG88

## AVOID HARMFUL ASBESTOS DUST

Avoid breathing dust that may be generated when handling components containing asbestos fibers. Inhaled asbestos fibers may cause lung cancer.

Components in products that may contain asbestos fibers are brake pads, brake band and lining assemblies, clutch plates, and some gaskets. The asbestos used in these components is usually found in a resin or sealed in some way. Normal handling is not hazardous as long as airborne dust containing asbestos is not generated.

Avoid creating dust. Never use compressed air for cleaning. Avoid brushing or grinding material containing asbestos. When servicing, wear an approved respirator. A special vacuum cleaner is recommended to clean asbestos. If not available, apply a mist of oil or water on the material containing asbestos.

Keep bystanders away from the area.

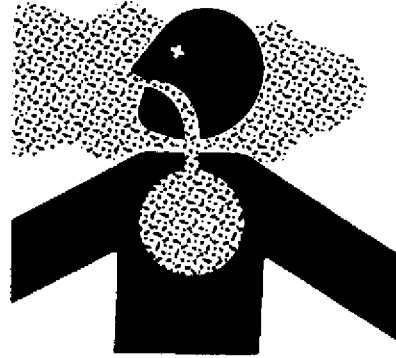

DX,DUST -19-15MAR91

TS220 -JUN-23AUG88

05  
05  
7

## AVOID HEATING NEAR PRESSURIZED FLUID LINES

Flammable spray can be generated by heating near pressurized fluid lines, resulting in severe burns to yourself and bystanders. Do not heat by welding, soldering, or using a torch near pressurized fluid lines or other flammable materials. Pressurized lines can be accidentally cut when heat goes beyond the immediate flame area.



DX,TORCH -19-05OCT90

TSS63 -JUN-15MAY90

05  
05-8

## REMOVE PAINT BEFORE WELDING OR HEATING

Avoid potentially toxic fumes and dust.

Hazardous fumes can be generated when paint is heated by welding, soldering, or using a torch.

Do all work outside or in a well ventilated area. Dispose of paint and solvent properly.

Remove paint before welding or heating:

- If you sand or grind paint, avoid breathing the dust. Wear an approved respirator.
- If you use solvent or paint stripper, remove stripper with soap and water before welding. Remove solvent or paint stripper containers and other flammable material from area. Allow fumes to disperse at least 15 minutes before welding or heating.

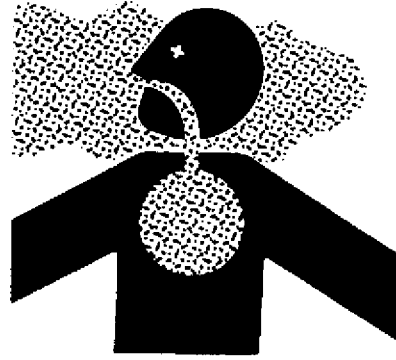

TS220 -JUN-23AUG88

DX,PAINT -19-04JUN90

## USE PROPER TOOLS

Use tools appropriate to the work. Makeshift tools and procedures can create safety hazards.

Use power tools only to loosen threaded parts and fasteners.

For loosening and tightening hardware, use the correct size tools. DO NOT use U.S. measurement tools on metric fasteners. Avoid bodily injury caused by slipping wrenches.

Use only service parts meeting John Deere specifications.



TS779 -JUN-08NOV89

DX,REPAIR -19-04JUN90

## DISPOSE OF WASTE PROPERLY

Improperly disposing of waste can threaten the environment and ecology. Potentially harmful waste used with John Deere equipment include such items as oil, fuel, coolant, brake fluid, filters, and batteries.

Use leakproof containers when draining fluids. Do not use food or beverage containers that may mislead someone into drinking from them.

Do not pour waste onto the ground, down a drain, or into any water source.

Air conditioning refrigerants escaping into the air can damage the Earth's atmosphere. Government regulations may require a certified air conditioning service center to recover and recycle used air conditioning refrigerants.

Inquire on the proper way to recycle or dispose of waste from your local environmental or recycling center, or from your John Deere dealer.

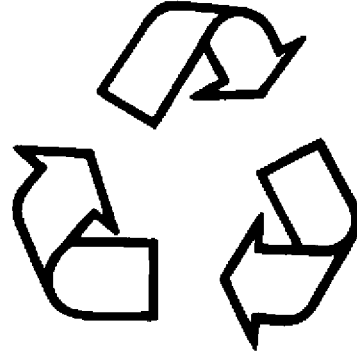

DX,DRAIN -19-09AUG91

05  
9  
TS1133 -JUN-26NOV90

## LIVE WITH SAFETY

Before returning machine to customer, make sure machine is functioning properly, especially the safety systems. Install all guards and shields.



DX,LIVE -19-04JUN90

TS231 -19-07OCT88

05  
05  
10



# Section 10 GENERAL INFORMATION

## Contents

### Page

#### Group 05—Machine Specifications

Specifications . . . . .	10-05-1
Abbreviations . . . . .	10-05-6

#### Group 10—Predelivery

Dealer Predelivery Service . . . . .	10-10-1
--------------------------------------	---------

#### Group 15—Tune-up

Specifications . . . . .	10-15-1
8960 Engine Repair-See Cummins Authorized Dealer . . . . .	10-15-2
Perform Preliminary Engine Tests-8560 and 8760 . . . . .	10-15-2
Tune-up and Adjustments . . . . .	10-15-3
Perform Final Engine Test . . . . .	10-15-3

#### Group 20—Lubrication

Lubricate Tractor Properly . . . . .	10-20-1
Diesel Engine Oil . . . . .	10-20-2
Anti-Chatter Transmission/Hydraulic Oil . . . . .	10-20-3
Grease . . . . .	10-20-3
Specifications . . . . .	10-20-4



**GENERAL SPECIFICATIONS**

	8560	8760	8960
<b>Power:</b>			
Engine (Factory observed)	235 hp (175 kW)	300 hp (224 kW)	370 hp (276 kW)
PTO (Factory observed)	198 hp (148 kW)	256 hp (191 kW)	322 hp (240 kW)
Rated speed	2100 rpm	2100 rpm	1900 rpm
Governed speed range	800—2300 rpm	800—2300 rpm	800—2100 rpm
Operating speed range	1500—2100 rpm	1500—2100 rpm	1500—1900 rpm
<b>Engine:</b>			
Type	in-line 6-cylinder, valve-in-head, turbocharged, and air-to-air aftercooled diesel		in-line 6-cylinder, valve-in-head, turbocharged and water-to-air aftercooled
Displacement	466 cu in. (7.6 L)	619 cu in. (10.1L)	855 cu in. (14.0L)
Bore	4.56 in. (116 mm)	5.12 in. (130 mm)	5.50 in. (140 mm)
Stroke	4.75 in. (121 mm)	5.00 in. (127 mm)	6.0 in. (152 mm)
Compression ratio	16.0:1	15.2:1	14.0:1
Lubrication	full-flow filtration w/bypass	full-flow filtration w/bypass	full-flow filtration w/bypass
<b>Fuel System:</b>			
Injection pump type	in-line	in-line	Cummins Pressure-Time
Fuel filter	dual-stage, metal-enclosed	throwaway type element	spin-on throwaway
Number fuel filters	single	single	single
Air cleaner	dry-type with secondary element	dry-type with secondary element	dry-type with secondary element
<b>Cooling System:</b>			
Fan	viscous drive	viscous drive	viscous drive
Number of thermostats	2	3	1
<b>Electrical System:</b>			
Type	12 volt	12 volt	12 volt
Alternator	negative ground 120 amp	negative ground 120 amp	negative ground 120 amp
Batteries	two 12 volt	two 12 volt	three 12 volt
Cold cranking amps	1850	1850	2775
<b>Capacities:</b>			
Fuel tank	220 gal (835L)	220 gal (835L)	220 gal (835L)
Cooling system	58 qt (55L)	58 qt (55L)	72 qt (68.1L)
Crankcase	23 qt (22L)	36.5 qt (34.5L)	39 qt (37L)
Transmission (all types)	10 gal (37.8L)	10 gal (37.8L)	10 gal (37.8L)
Hydraulic system:			
Total	38 gal (144L)	38 gal (144L)	40 gal (151L)
Hydraulic reservoir	14 gal (53L)	14 gal (53L)	14 gal (53L)

RX14331010,1 -19-07MAY91

10  
05  
2

**Hydraulic System:**

Type . . . . . Closed-Center, Pressure Compensating  
Main Hydraulic Pump . . . . . 8-Piston, Variable Displacement  
Displacement . . . . . 4 cu in. (65 cm<sup>3</sup>)  
Standby Pressure . . . . . 2530 psi (17 500 kPa) (175 bar)  
Steering System . . . . . Hydrostatic Power  
Hitch Lift Capacity . . . . . 13490 lb (6323 kg)

**Brakes:**

Type . . . . . Hydraulically Operated Wet Disk

**Transmissions:**

12-Speed Syncro:  
Type . . . . . Hydraulically Activated Wet Disk Clutch  
Gear Selections . . . . . 12 Forward, 3 Reverse  
  
24-Speed POWRSYNC:  
Type . . . . . Hydraulically Activated Wet Disk Clutch and Hi-Lo Clutch  
Gear Selections . . . . . 24 Forward, 6 Reverse  
  
12-Speed Powershift:  
Type . . . . . Electronically Activated Wet Clutch  
Gear Selections . . . . . 12 Forward, 2 Reverse

**Power Take-Off:**

Type . . . . . Fully Independent  
Speed . . . . . 1000 rpm  
Size . . . . . 1-3/4 in. (45 mm)  
Clutch . . . . . Multiple Wet-Disk Hydraulically Activated

RX14331010,2 -19-07MAY91

*Machine Specifications/Specifications*

	<b>8560</b> <b>(18.4-38 duals)</b>	<b>8760</b> <b>(20.8-38 duals)</b>	<b>8960</b> <b>(20.8-42 duals)</b>
<b>Overall Dimensions:</b>			
Wheelbase	134.0 in. (3400 mm)	134.0 in. (3400 mm)	134.0 in. (3400 mm)
Overall Length	268.9 in. (6830 mm)	268.9 in. (6830 mm)	268.9 in. (6830 mm)
Width (center of outer duals)	119.8 in. (3042 mm)	119.8 in. (3042 mm)	119.8 in. (3042 mm)
Height			
Top of SOUND-GARD	134.3 in. (3410 mm)	135.8 in. (3440 mm)	137.4 in. (3491 mm)
Top of Hood	95.9 in. (2436 mm)	97.1 in. (2466 mm)	99.1 in. (2517 mm)
Top of Muffler	151.7 in. (3852 mm)	152.8 in. (3882 mm)	154.8 in. (3933 mm)
Turning Radius	14.6 ft (4.45 m)	14.6 ft (4.45 m)	14.6 ft (4.45 m)
Crop Clearance (axle)	18.8 in. (477 mm)	20.0 in. (507 mm)	22.0 in. (558 mm)
Estimated Shipping Weight (No PTO - No Hitch)	28260 lb (12 819 kg)	29720 lb (13 481 kg)	31320 lb (14 188 kg)
Tires (standard)	18.4R-38 in.	20.8R-38 in.	20.8R-42 in.

RX14331010,3 -19-22MAY91

10  
05  
3

## METRIC BOLT AND CAP SCREW TORQUE VALUES

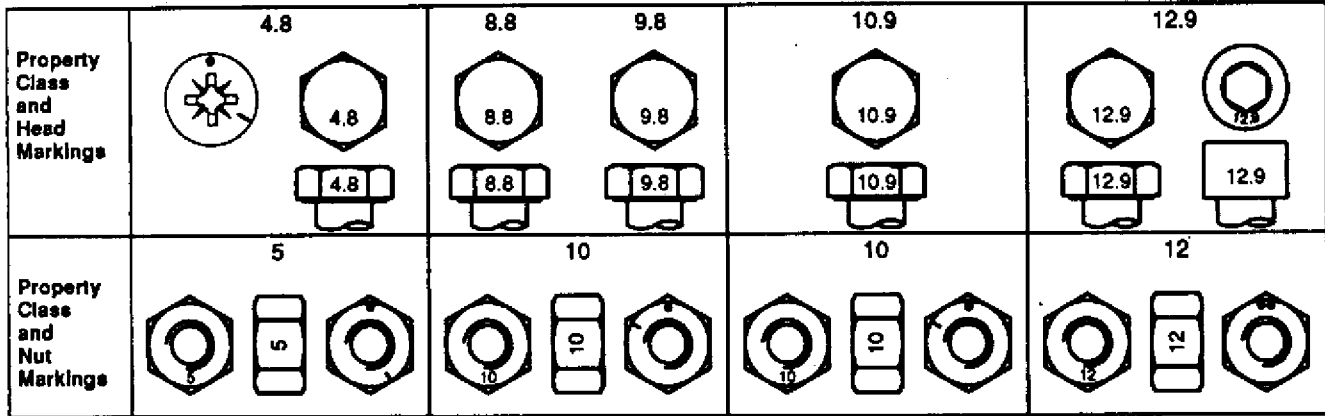

Size	Class 4.8				Class 8.8 or 9.8				Class 10.9				Class 12.9			
	Lubricated <sup>a</sup>		Dry <sup>a</sup>		Lubricated <sup>a</sup>		Dry <sup>a</sup>		Lubricated <sup>a</sup>		Dry <sup>a</sup>		Lubricated <sup>a</sup>		Dry <sup>a</sup>	
	N·m	lb-ft	N·m	lb-ft	N·m	lb-ft	N·m	lb-ft	N·m	lb-ft	N·m	lb-ft	N·m	lb-ft	N·m	lb-ft
M6	4.8	3.5	6	4.5	9	6.5	11	8.5	13	9.5	17	12	15	11.5	19	14.5
M8	12	8.5	15	11	22	16	28	20	32	24	40	30	37	28	47	35
M10	23	17	29	21	43	32	55	40	63	47	80	60	75	55	95	70
M12	40	29	50	37	75	55	95	70	110	80	140	105	130	95	165	120
M14	63	47	80	60	120	88	150	110	175	130	225	165	205	150	260	190
M16	100	73	125	92	190	140	240	175	275	200	350	225	320	240	400	300
M18	135	100	175	125	260	195	330	250	375	275	475	350	440	325	560	410
M20	190	140	240	180	375	275	475	350	530	400	675	500	625	460	800	580
M22	260	190	330	250	510	375	650	475	725	540	925	675	850	625	1075	800
M24	330	250	425	310	650	475	825	600	925	675	1150	850	1075	800	1350	1000
M27	490	360	625	450	950	700	1200	875	1350	1000	1700	1250	1600	1150	2000	1500
M30	675	490	850	625	1300	950	1650	1200	1850	1350	2300	1700	2150	1600	2700	2000
M33	900	675	1150	850	1750	1300	220	1650	2500	1850	3150	2350	2900	2150	3700	2750
M36	1150	850	1450	1075	2250	1650	2850	2100	3200	2350	4050	3000	3750	2750	4750	3500

DO NOT use these values if a different torque value or tightening procedure is given for a specific application. Torque values listed are for general use only. Check tightness of fasteners periodically.

Shear bolts are designed to fail under predetermined loads. Always replace shear bolts with identical property class.

Fasteners should be replaced with the same or higher property class. If higher property class fasteners are used, these should only be tightened to the strength of the original.

<sup>a</sup> "Lubricated means coated with a lubricant such as engine oil, or fasteners with phosphate and oil coatings. "Dry means plain or zinc plated without any lubrication.

Make sure fasteners threads are clean and that you properly start thread engagement. This will prevent them from failing when tightening.

Tighten plastic insert or crimped steel-type lock nuts to approximately 50 percent of the dry torque shown in the chart, applied to the nut, not to the bolt head. Tighten toothed or serrated-type lock nuts to the full torque value.

**UNIFIED INCH BOLT AND CAP SCREW TORQUE VALUES**

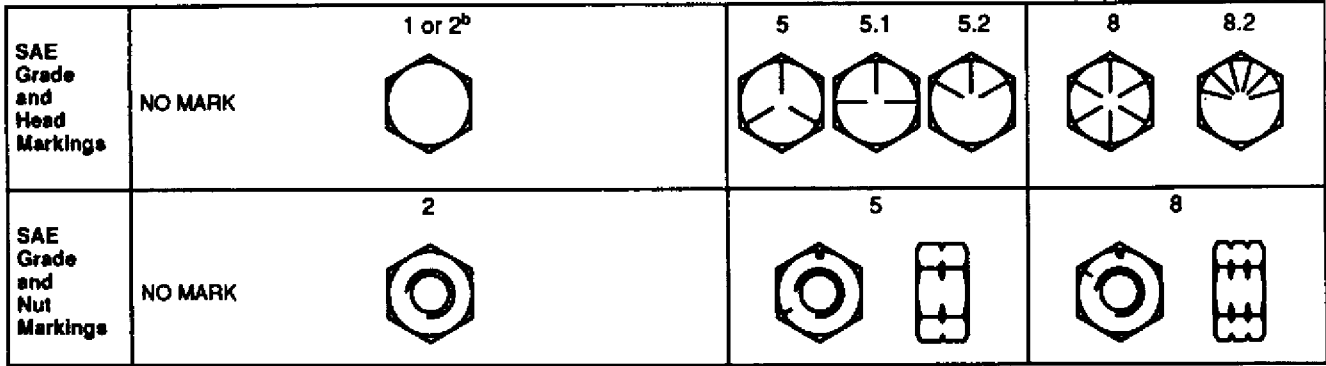

Size	Grade 1				Grade 2 <sup>b</sup>				Grade 5, 5.1, or 5.2				Grade 8 or 8.2			
	Lubricated <sup>a</sup>		Dry <sup>a</sup>		Lubricated <sup>a</sup>		Dry <sup>a</sup>		Lubricated <sup>a</sup>		Dry <sup>a</sup>		Lubricated <sup>a</sup>		Dry <sup>a</sup>	
	N·m	lb-ft	N·m	lb-ft	N·m	lb-ft	N·m	lb-ft	N·m	lb-ft	N·m	lb-ft	N·m	lb-ft	N·m	lb-ft
1/4	3.7	2.8	4.7	3.5	6	4.5	7.5	5.5	9.5	7	12	9	13.5	10	17	12.5
5/16	7.7	5.5	10	7	12	9	15	11	20	15	25	18	28	21	35	26
3/8	14	10	17	13	22	16	27	20	35	26	44	33	50	36	63	46
7/16	22	16	28	20	35	26	44	32	55	41	70	52	80	58	100	75
1/2	33	25	42	31	53	39	67	50	85	63	110	80	120	90	150	115
9/16	48	36	60	45	75	56	95	70	125	90	155	115	175	130	225	160
5/8	67	50	85	62	105	78	135	100	170	125	215	160	215	160	300	225
3/4	120	87	150	110	190	140	240	175	300	225	375	280	425	310	550	400
7/8	190	140	240	175	190	140	240	175	490	360	625	450	700	500	875	650
1	290	210	360	270	290	210	360	270	725	540	925	675	1050	750	1300	975
1-1/8	470	300	510	375	470	300	510	375	900	675	1150	850	1450	1075	1850	1350
1-1/4	570	425	725	530	570	425	725	530	1300	950	1650	1200	2050	1500	2600	1950
1-3/8	750	550	950	700	750	550	950	700	1700	1250	2150	1550	2700	2000	3400	2550
1-1/2	1000	725	1250	925	990	725	1250	930	2250	1650	2850	2100	3600	2650	4550	3350

DO NOT use these values if a different torque value or tightening procedure is given for a specific application. Torque values listed are for general use only. Check tightness of fasteners periodically.

Shear bolts are designed to fail under predetermined loads. Always replace shear bolts with identical grade.

<sup>a</sup> "Lubricated" means coated with a lubricant such as engine oil, or fasteners with phosphate and oil coatings. "Dry" means plain or zinc plated without any lubrication.

<sup>b</sup> Grade 2 applies for hex cap screws (not hex bolts) up to 152 mm (6-in.) long. Grade 1 applies for hex cap screws over 152 mm (6-in.) long, and for all other types of bolts and screws of any length.

Fasteners should be replaced with the same or higher grade. If higher grade fasteners are used, these should only be tightened to the strength of the original.

Make sure fasteners threads are clean and that you properly start thread engagement. This will prevent them from failing when tightening.

Tighten plastic insert or crimped steel-type lock nuts to approximately 50 percent of the dry torque shown in the chart, applied to the nut, not to the bolt head. Tighten toothed or serrated-type lock nuts to the full torque value.

## ABBREVIATIONS

Abbreviations are used in place of some words.

AQS—Air Quality System

CTM—Component Technical Manual

ECU—Engine Control Unit

EFI—Electronic Fuel Injection

ID—Inside Diameter

MST—Manual Shift Transmission

OD—Outside Diameter

ORS—O-Ring Seal

PST—Power Shift Transmission

PTO—Power Take-Off

SCV—Selective Control Valve

SMV—Slow Moving Vehicle

SGB—SOUND-GARD Body

RX14331010,7 -19-05MAR91

10  
05  
6



**DEALER PREDELIVERY SERVICE**

The John Deere delivery receipt, when properly filled out and signed by the dealer and customer, verifies predelivery and delivery services were satisfactorily performed. When delivering the tractor, give the customer his copy of the delivery receipt and operators manual. Be sure to explain their purposes to him.

Because of the shipping factors involved, plus extra finishing touches necessary to promote customer satisfaction, there are certain predelivery services that must be performed by the dealer. These services are listed in the first of two sections on the predelivery form which is attached to the tractor. The second section is a list of factory inspections that must be verified by the dealer.

Fill the form out completely and sign it. Send a copy to the factory and file the original with the shop order for the job. This will certify the proper delivery service has been completed.

Perform all services listed and check each job off as it is completed.

10  
10  
1

10  
2010

**SPECIFICATIONS**

Item	Measurement	Specification
Radiator	Pressure Test	70—105 kPa (0.7—1.1 bar) (10—15 psi)
Radiator Cap	Pressure Test	85—105 kPa (0.9—1.1 bar) (12—15 psi)
Engine:		
8560	Compression	2380—2790 kPa (23.8—27.9 bar) (345—405 psi)
8760	Compression	2280—2605 kPa (22.8—26.1 bar) (330—380 psi)
Thermostat	Opening Temperature	82°C (180°F)
Air Conditioning Compressor Belt:		
All Models		
New Belt	Tension	580—620 N (130—140 lb force)
After Break In*	Tension	380—420 N (85—95 lb force)
Fan and Alternator Belt:		
8560		
New Belt	Tension	425—465 N (95—105 lb force)
After Break In*	Tension	330—370 N (74—84 lb force)
8760		
New Belt	Tension	490—670 N (110—150 lb force)
After Break In*	Tension	355—445 N (80—100 lb force)
8960		
New Belt	Tension	1020—1110 N (230—250 lb force)
After Break In*	Tension	712—890 N (160—280 lb force)
Slow Idle	rpm (all models)	775—825
Fast Idle:		
8560-8760	rpm	2275—2325
8960	rpm	2025—2075
Fast Idle at Full Load:		
8560-8760	rpm	2100
8960	rpm	1900

\* Break-in period is 10 minutes

RX14331020,1 -19-10APR90

## 8960 ENGINE REPAIR—SEE CUMMINS AUTHORIZED DEALER

Only Cummins Engine Company, its distributors, or servicing dealers are authorized to service the NTA 855 Engine.

Engine warranty may be void on any unauthorized service.

If your dealership is authorized to service this engine, refer to the Cummins service literature.

RX14331020,2 -19-10APR90

## PERFORM PRELIMINARY ENGINE TESTS—8560 AND 8760

Before tuning up a tractor, determine if a tune-up will restore operating efficiency. Perform the following preliminary tests:

- Loosen crankcase drain plug and check for water seepage after engine has been stopped for several hours. A few drops could be due to condensation, but any more would indicate the need for engine repair.
- Inspect coolant for oil film with engine stopped. Inspect coolant for air bubbles with engine running. Either condition would indicate the need for engine repair.
- Perform dynamometer test. Record horsepower. (See Dynamometer Test—TM1434, Section 220.)
- Perform compression test. (See CTM6 or CTM42 for 6076 Engines, or CTM20, for 6101 Engines.)
- Perform Tune-up

RX14331020,3 -19-20MAR92

## TUNE-UP AND ADJUSTMENTS

Inspect the following for tractor tune-up:

### Engine

- Change oil and filter
- Clean crankcase vent tube (Sec 20—Grp 05)
- Adjust valve clearance (See CTM for 8560 and 8760 or Cummins authorized dealer for 8960)

### Air Intake System

- Inspect air cleaners (Sec 30—Grp 05)
- Tighten air intake connections (Sec 30—Grp 05)
- Check air intake restriction (Sec 30—Grp 05)

### Cooling System

- Clean grille screens, radiator, and oil cooler (Sec 20—Grp 10)
- Flush cooling system (Sec 20—Grp 10)
- Test radiator and cap (Sec 20—Grp 10)
- Replace engine coolant-conditioner filter (Sec 20—Grp 10)
- Inspect and adjust belts (Sec 20—Grp 10)
- Inspect hoses

### Fuel System

- Check fuel tanks for water
- Replace fuel filters (Sec 30—Grp 10)
- Adjust injection pump timing (Sec 30—Grp 10)
- Bleed fuel system (Sec 30—Grp 10)
- Adjust slow and fast idle (Sec 30—Grp 10)

### Electrical System

- Service batteries (Sec 40—Grp 01)
- Inspect battery cables
- Inspect and adjust alternator belt (Sec 40—Grp 15)
- Check neutral start switch (Sec 40—Grp 20)

### Hydraulic System

- Clean hydraulic breather (Sec 70—Grp 25)
- Change oil and filter

### Lubrication

- See Lubrication—Group 20

RX14331020,3A -19-08MAY91

## PERFORM FINAL ENGINE TEST

Repeat dynamometer test. (See Dynamometer Test—TM1434, Section 220.) Record and compare performance with previous test.

RX14331020,36 -19-20MAR92

*Tune-up/Perform Final Engine Test*

10  
15  
4

## **LUBRICATE TRACTOR PROPERLY**

**IMPORTANT:** Correct selection and proper use of lubricating oils and grease is very important in keeping upkeep costs low, while providing long tractor life with satisfactory service.

Use only lubricants specified in this section. Lubricate at the intervals listed and according to the following instructions.

RX14331025,1 -19-10APR90

10  
20  
1

## DIESEL ENGINE OIL

Use oil viscosity based on the expected air temperature range during the period between oil changes.

John Deere TORQ-GARD SUPREME PLUS-50™ engine oil is recommended. This oil is specially formulated to provide superior protection against high temperature thickening and wear as well as exceptional cold weather starting performance; these properties allow an extended drain interval and may result in longer engine life.

If John Deere TORQ-GARD SUPREME PLUS-50 engine oil and a John Deere oil filter are used, the oil and filter change interval may be extended by 50 hours.

John Deere TORQ-GARD SUPREME® engine oil is also recommended. Other oils may be used if they meet one or more of the following:

- API Service Classification CE or CD
- Military Specification MIL-L-2104E or MIL-L-2104D or MIL-L-2104C

SAE 5W20, SAE 5W30, and arctic oil viscosity grades meeting API Service Classification CC may be used, but oil and filter must be changed at one-half the normal interval.

Oils meeting Military Specification MIL-L-46167B may be used as arctic oils.

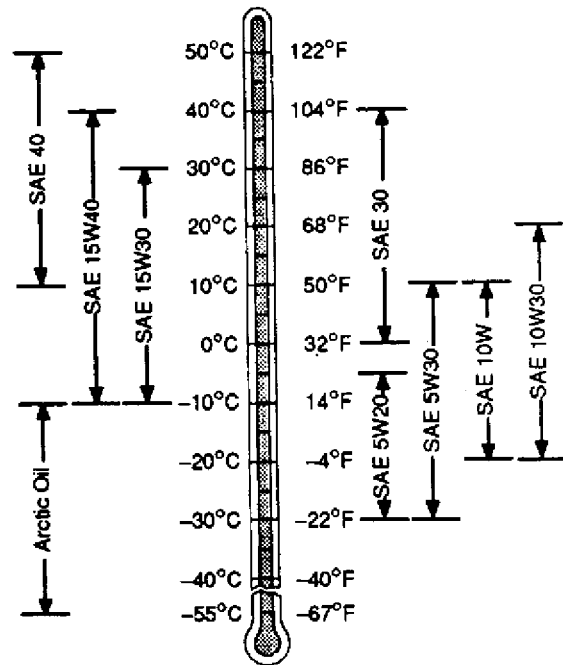

TS238 -19-17MAY91



## ANTI-CHATTER TRANSMISSION/HYDRAULIC OIL

Use oil viscosity based on the expected air temperature range during the period between oil changes.

John Deere HY-GARD® Transmission/Hydraulic Oil is recommended. HY-GARD oil is specially formulated to minimize wet brake chatter, to provide optimum clutch engagement, and to provide maximum protection against mechanical wear, corrosion, and foaming.

Other oils may be used if they are QUATROL® oils or if they meet John Deere Standard JDM J20A or J20B.

Oils meeting Military Specification MIL-L-46167A may be used as arctic oils.

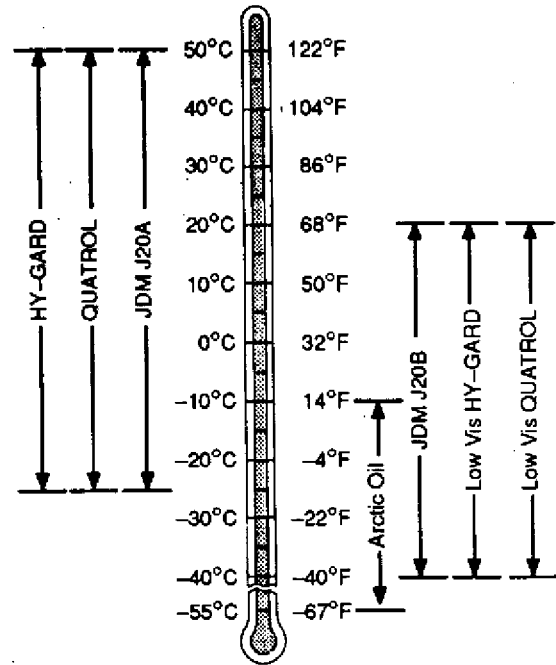

DX.ANTI -19-05JUN91

10  
20  
3  
TS240 -19-28NOV90

## EXTREME PRESSURE OR MULTIPURPOSE GREASE

Use grease based on the expected air temperature range during the service interval.

John Deere Moly High Temperature EP Grease and John Deere High Temperature EP Grease are recommended.

Other greases that may be used are:

- SAE Multipurpose EP Grease with 3 to 5 percent molybdenum disulfide.
- SAE Multipurpose EP Grease.
- Greases meeting Military Specification MIL-G-10924C may be used as arctic grease.

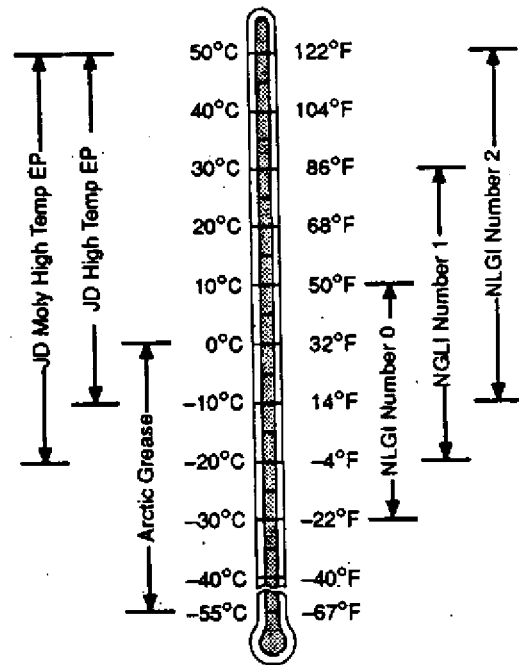

DX.GREA1 -19-15MAR91

TS248 -19-28NOV90

## LUBRICATION SERVICE INTERVALS

### Engine:

Check Oil Level . . . . .	10 Hours
Change Oil and Filter * ** . . . . .	250 Hours
Grease Fan Pillow Blocks (8960) . . . . .	250 Hours, Annually, and as Required
Clean Crankcase Vent Tube . . . . .	750 Hours

### Transmission:

Check Oil Level . . . . .	10 Hours
Change Transmission Oil Filter * . . . . .	750 Hours and as Required
Change Oil . . . . .	1500 Hours
Clean Sump Screen . . . . .	1500 Hours

### Hydraulic System:

Check Oil Level . . . . .	10 Hours
Change Hydraulic Oil Filter * . . . . .	750 Hours and as Required
Change Oil . . . . .	1500 Hours
Change Differential Oil . . . . .	1500 Hours
Clean Axle/PTO Pump Sump Screen . . . . .	As Required
Clean Charge Pump Sump Screen . . . . .	As Required
Clean Main Hydraulic Pump Screen . . . . .	As Required

### Lubrication of Grease Fittings:

Axle Bearings (wet conditions) . . . . .	10 Hours
Axle Bearings (normal conditions) . . . . .	500 Hours
Hinge Pins . . . . .	10 Hours
3-Point Hitch Lift Cylinder Pins and Lift Arms . . . . .	10 Hours
Gudgeon Spindle Bearings . . . . .	250 Hours
Telescoping Drive Shafts . . . . .	250 Hours
Lower Driveline Bearing . . . . .	250 Hours
3-Point Hitch Center Link and Lift Links . . . . .	250 Hours
Seat Sliding and Swiveling Surfaces . . . . .	As Required

\* Change at 100 Hours during break-in period

\*\* Interval may be extended by 50 hours if John Deere TORQ-GARD SUPREME PLUS-50 is used. This does not apply to other service intervals.

RX14331025,2 -19-22MAY91

10  
20  
4

# Section 15

# Component Removal

## Contents

	Page	Page
<b>Group 00—Major Components</b>		
		Other Material . . . . . 15-30-2
		Specifications . . . . . 15-30-2
		Remove Power Shift Transmission . . . . . 15-30-3
		Install Transmission on Engine Rotation Stand . . . . . 15-30-7
		Install Power Shift Transmission . . . . . 15-30-8
		Replace Transmission Mounting Pins and Bushings . . . . . 15-30-8
<b>Group 05—Front Axles and Final Drives</b>		
Special or Essential Tools . . . . .	15-05-1	
Service Equipment and Tools . . . . .	15-05-1	
Specifications . . . . .	15-05-1	
Remove Front Axle and Final Drives . . . . .	15-05-2	
Install Front Axle and Final Drives . . . . .	15-05-3	
<b>Group 10—Rear Axles and Final Drives</b>		
Special or Essential Tools . . . . .	15-10-1	
Service Equipment and Tools . . . . .	15-10-1	
Specifications . . . . .	15-10-1	
Remove Rear Axle and Final Drives . . . . .	15-10-2	
Install Rear Axle and Final Drives . . . . .	15-10-4	
<b>Group 15—Engine</b>		
Special or Essential Tools . . . . .	15-15-1	
Service Equipment and Tools . . . . .	15-15-1	
Specifications . . . . .	15-15-2	
Remove Engine . . . . .	15-15-2	
Install Engine . . . . .	15-15-5	
<b>Group 20—SOUND-GARD Body</b>		
Special or Essential Tools . . . . .	15-20-1	
Specifications . . . . .	15-20-1	
Remove SOUND-GARD Body . . . . .	15-20-2	
Install SOUND-GARD Body . . . . .	15-20-9	
<b>Group 25—Mechanical Shift Transmission</b>		
Special or Essential Tools . . . . .	15-25-1	
Service Equipment and Tools . . . . .	15-25-1	
Other Material . . . . .	15-25-2	
Specifications . . . . .	15-25-2	
Remove Mechanical Shift Transmission . . . . .	15-25-3	
Install Transmission on Engine Rotation Stand . . . . .	15-25-8	
Install Mechanical Shift Transmission . . . . .	15-25-9	
Replace Transmission Mounting Pins and Bushings . . . . .	15-25-10	
<b>Group 30—Power Shift Transmission</b>		
Special or Essential Tools . . . . .	15-30-1	
Service Equipment and Tools . . . . .	15-30-1	



MAJOR COMPONENTS—EXPLODED VIEW

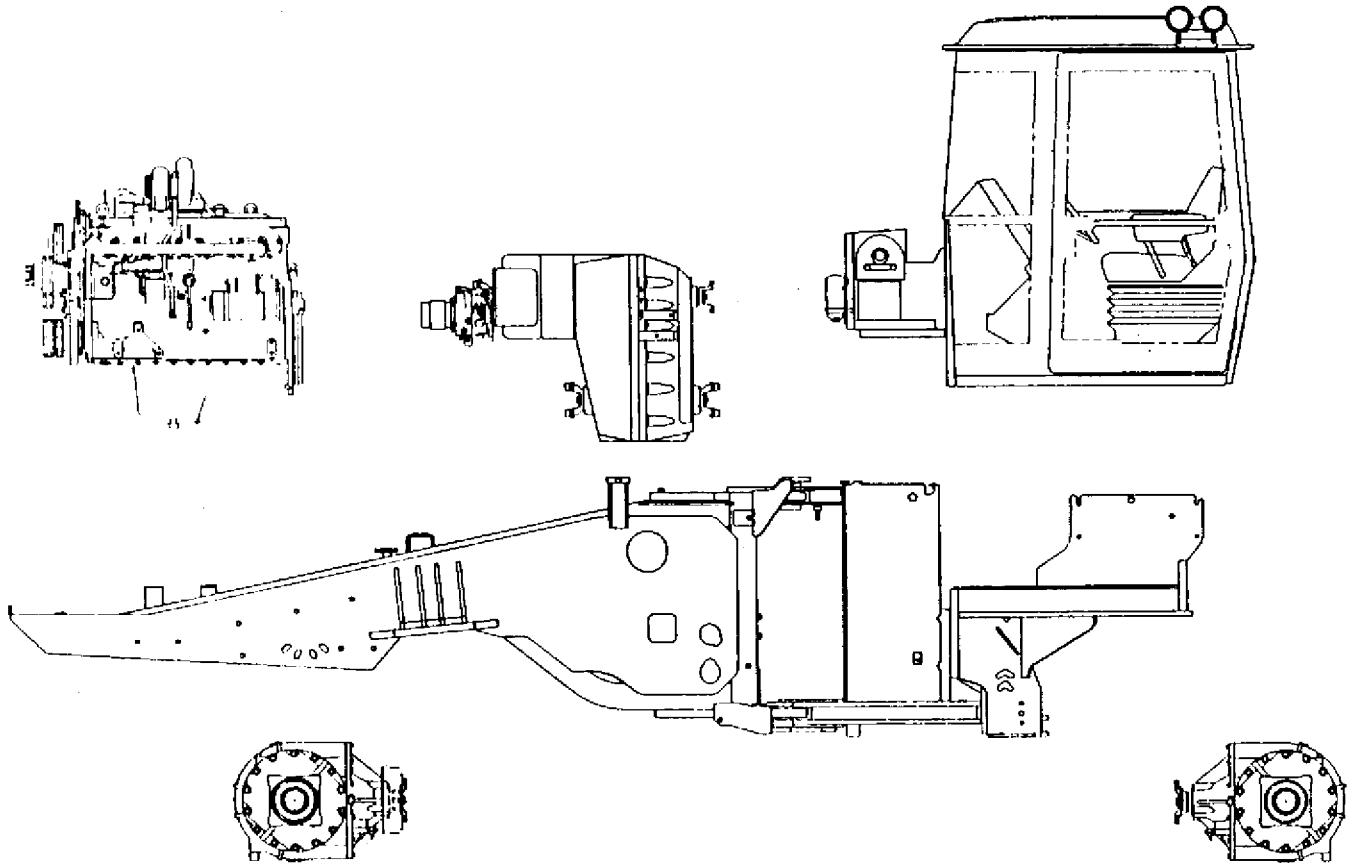

15  
00  
1

RW14015 -JUN-02APR90

RX14331500,1 -19-10APR90

*Major Components*

15  
00  
2

**SPECIAL OR ESSENTIAL TOOLS**

*NOTE: Order tools according to information given in the U.S. SERVICE-GARD™ Catalog or in the European Microfiche Tool Catalog (MTC).*

DX,TOOLS -19-05JUN91

Gudgeon Oscillation Stop . . . . . JDG660

RW18082 -UN-09APR90

Prevents gudgeon oscillation during axle removal

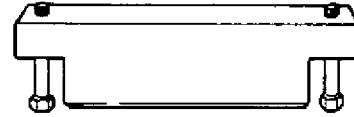

JDG660 -19-10APR90

**SERVICE EQUIPMENT AND TOOLS**

*NOTE: Order tools from the U.S. SERVICEGARD™ Catalog or from the European Microfiche Tool Catalog (MTC). Some tools may be available from a local supplier.*

Name	Use
D05124ST Torque Multiplier	Remove and install axle mounting cap screws
* DFRW22 Balancer Tool	Aid in axle and final drive removal or installation

\* Dealer Fabricated Tool—See Section 99

RX14331505,1 -19-10APR90

**SPECIFICATIONS**

Item	Measurement	Specification
Axle Housing to Frame Mounting Cap Screws	Torque	1070 N·m (790 lb-ft)
Drive Shaft Cap Screws	Torque	150 N·m (110 lb-ft)

RX14331505,4B -19-31JAN92

15  
05  
1

## AXLE AND FINAL DRIVE REPAIR— USE CTM-18

For complete repair information on the 1600 Series Axles, component technical manual (CTM-18) is also required.

Use the component technical manual in conjunction with this machine manual.



RW14298 -UN-13DEC88

RX14331505.3 -19-30JAN92

## REMOVE FRONT AXLE AND FINAL DRIVES

**For tractors with PST, perform Steps 1a and 1b.**

- 1a. Block rear wheels.
- 1b. Disconnect park brake cable at front axle.

**For tractors with MST, perform Step 1c.**

- 1c. Put transmission lever in "PARK" position.

RX14331505.4 -19-31JAN92

2. Disconnect drive shaft from axle.
3. Drain oil from axle assembly.
4. Disconnect hoses from axle.
5. Install JDG660 Gudgeon Oscillation Stop (A) to keep rear frame from oscillating.
6. Install stand under gudgeon (B).
7. Install jack stands under each side of front frame.
8. Remove tires from axle.



RW13392 -UN-05DEC88

RX14331505.1B -19-13DEC91



9. Attach hoist and straps or chains to each axle shaft.
10. Remove two outer axle mounting cap screws.

*NOTE: D05124ST Torque Multiplier may be needed to remove cap screws.*

11. Attach DFRW22 Balancer Tool (A) to bottom of axle, using the two cap screws removed. (See Dealer Fabricated Tools—Section 99.)

12. Remove remaining cap screws.

13. Remove axle from tractor.



RW13410  
-JUN-05DEC88

RX14331505,2B -19-13DEC91

## INSTALL FRONT AXLE AND FINAL DRIVES

1. Install axle to tractor and tighten mounting cap screws to 1070 N·m (790 lb-ft).

*NOTE: D05124ST Torque Multiplier may be needed to tighten cap screws.*

2. Tighten drive shaft cap screws to 150 N·m (110 lb-ft).
3. Connect park brake cable for PST.
4. Install front tires.
5. Check hydraulic oil level.

RX14331505,3B -19-30JAN92

15  
05  
3

15  
05  
4

## SPECIAL OR ESSENTIAL TOOLS

*NOTE: Order tools according to information given in the U.S. SERVICE-GARD™ Catalog or in the European Microfiche Tool Catalog (MTC).*

DX,TOOLS -19-05JUN91

Gudgeon Oscillation Stop . . . . . JDG660

RW18082 -UN-09APR90

Prevents gudgeon oscillation during axle removal

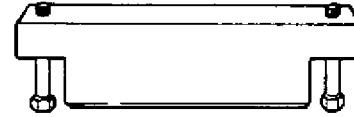

JDG660 -19-10APR90

## SERVICE EQUIPMENT AND TOOLS

*NOTE: Order tools from the U.S. SERVICEGARD™ Catalog or from the European Microfiche Tool Catalog (MTC). Some tools may be available from a local supplier.*

Name	Use
D05124ST Torque Multiplier	Remove and install axle mounting cap screws
* DFRW22 Balancer Tool	Aid in axle and final drive removal or installation

\* Dealer Fabricated Tool—See Section 99

RX14331505,1 -19-10APR90

## SPECIFICATIONS

Item	Measurement	Specification
Axle Housing to Frame Mounting Cap Screws	Torque	1070 N·m (790 lb-ft)
Drive Shaft Cap Screws	Torque	150 N·m (110 lb-ft)
Drawbar Support Stabilizer Link Cap Screws	Torque	620 N·m (460 lb-ft)
Rear Drawbar Support Cap Screws	Torque	620 N·m (460 lb-ft)

RX14331510,5B -19-31JAN92

## AXLE AND FINAL DRIVE REPAIR— USE CTM-18

For complete repair information on the 1600 Series Axles, component technical manual (CTM-18) is also required.

Use the component technical manual in conjunction with this machine manual.



RX14331505.3 -19-30JAN92

RW14298 -UN-13DEC88

## REMOVE REAR AXLE AND FINAL DRIVES

For tractors equipped WITH hitch and PTO, perform Steps 1—6. For tractors WITHOUT hitch and PTO, begin with Step 7.

1. Remove draft links, lift links, center link, and quick coupler.
2. Disconnect electrical harness from hitch control valve.
3. Disconnect lift cylinders from lift arm. Tie lift arm securely to brace (A).



RW13422 -UN-11JUN90

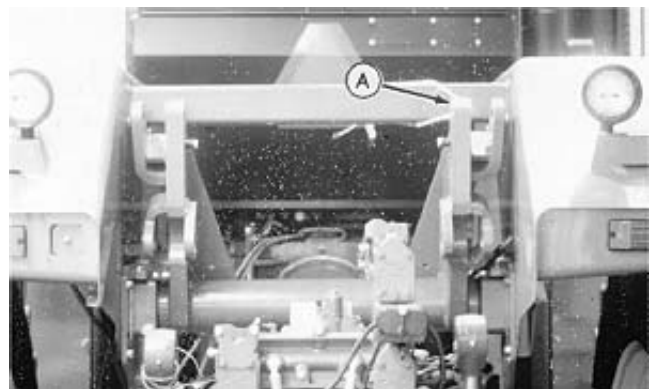

RW13388 -UN-11JUN90

RX14331510.2 -19-31JAN92

4. Disconnect driveshaft from PTO drop box.
5. Disconnect upper inlet hose and bottom return hose from PTO drop box.
6. Remove six support bracket cap screws (A).

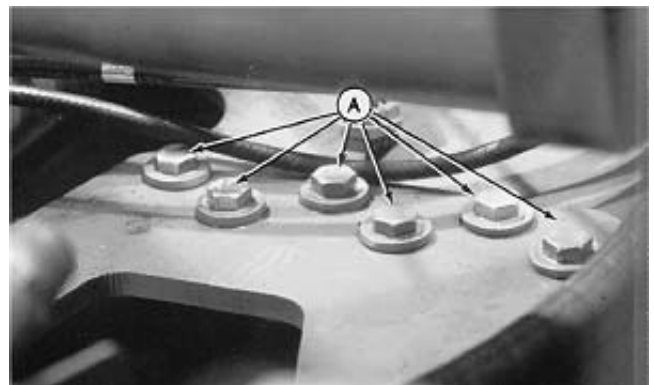

RW13387 -UN-11JUN90

RX14331510.3 -19-10APR90

**BUY NOW**

**Then Instant Download  
the Complete Manual  
Thank you very much!**